

Installation instructions for ECO "T" SEAT

Flat pack on arrival

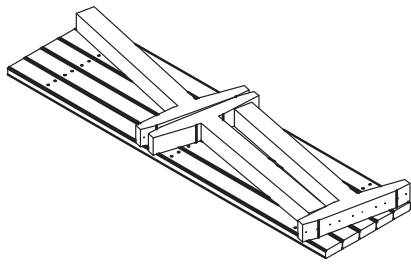

STEP 1: Place 95x45@1800 Profile on top of Eco T legs. Working from the outside in, screw through profile using 14gx75 screws. Be sure to align screws with marked holes in Eco Leg. Torque screws down being careful not to over tighten.

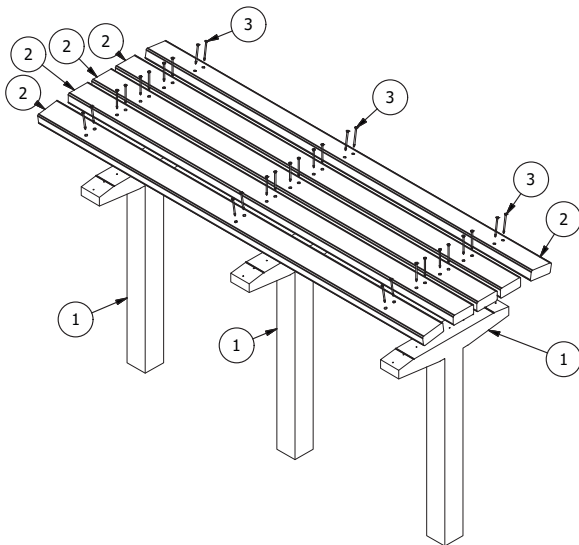

STEP 2: Auger Three 100mm holes at 700mm spacings approximately 400mm deep. Place loose stone into bottom of the holes until the required seat height is achieved. pour concrete into holes. Using a spirit level ensure seat is leveled correctly.

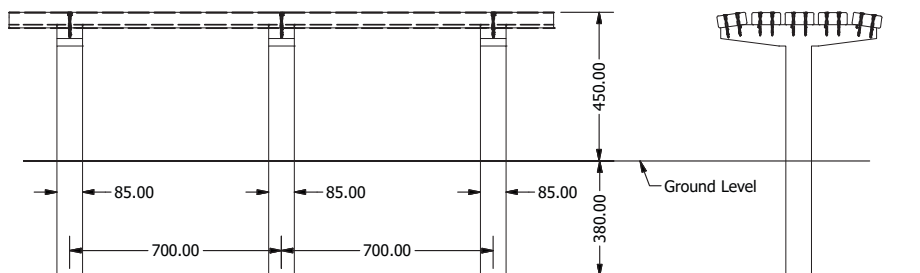

©Integrated Recycling P/L 2017

Parts List - Per Sleeve		
1	Composite Profile	3
2	95x40@1800 Dura comp Profile	5
3	14Gx100 Bugel Batten Screw	30

TOOLS REQUIRED:

- 5mm Allen Key or equivalent driver and drill
- Large Square
- Spirit Level

