

Installation instructions for BACKLESS CONTEMPORARY SEAT

Flat pack on arrival

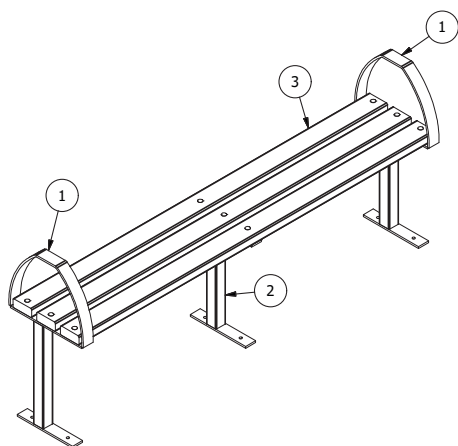

STEP 2: Place legs upright on level surface. Place three of the Dura Comp profiles on legs and lightly tap M8 bolts through profiles and holes through legs. Use washers and nuts then lightly tighten. Square completed seat then tighten all nuts being careful not to over tighten pulling bolts through profile.

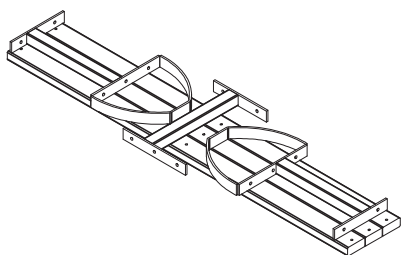
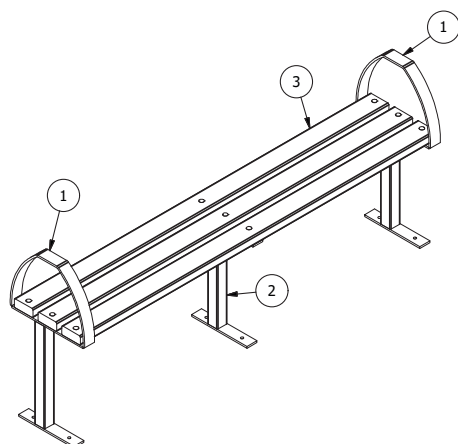

©Integrated Recycling P/L 2017

Parts List - Per Sleeve

1	Backless Contemporary seat with arm rest	2
2	Backless Contemporary seat center	1
3	95x40@1800 Dura Comp	3
4	M8x65 Gal Coach Bolt	9
5	M8 Washer	9
6	M8 Nut	9

TOOLS REQUIRED:

- Hammer
- Shifting Spanner

