

Assembly Instructions

CONTEMPORARY SEAT

Flat pack on arrival

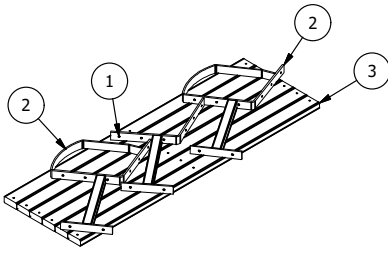

STEP 1: Place legs upright on level surface. Place three of the Duracomp profiles on legs and lightly tap M8 bolts through profiles and holes through legs. Use washers and nuts then lightly tighten.

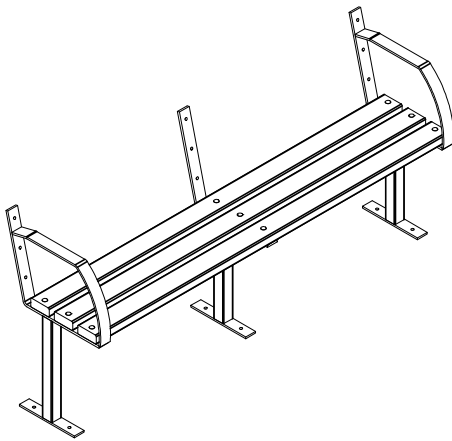

STEP 2: Place three of the Duracomp profiles on back rest and lightly tap M8 bolts through profiles and holes through legs. Use washers and nuts then lightly tighten. Square completed seat then tighten all nuts being careful not to over tighten pulling bolts through profile.

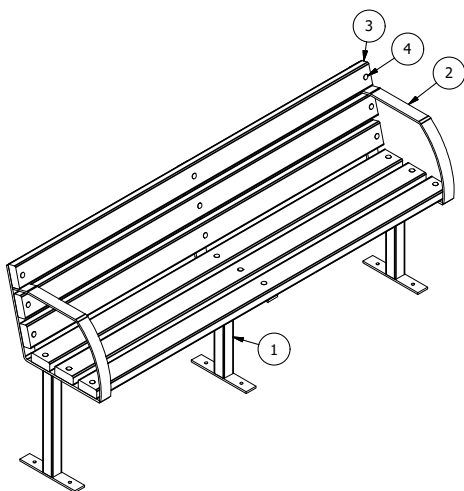

Parts List - Per Sleeve

1	Contemporary with back center	1
2	Contemporary with back	2
3	95x40@1800 Dura Comp	6
4	M8x65 Gal Coach Bolt	18
5	M8 Washer	18
6	M8 Nut	18

TOOLS REQUIRED:

- Hammer
- Shifting Spanner

